

The Lean Perspective

“The Lean Supply Chain”

(The Fourth in a 9 part series on Lean Enterprise, and the tools and techniques employed to affect change)
By Lee Ducharme and Pat Lucansky

In most organizations, supply chains are disconnected and business processes are not linked to suppliers or internal/external customer needs. In fact, very few organizations understand how to serve customers or end-users. Organizations that have successfully integrated their supply chains recognized they need to understand some basic ingredients found in ALL supply chains. These ingredients are defined as:

- A. Product Flow –the value-added movement of goods and services from the receipt of supplier raw material to delivery of product to customers.
- B. Customer Needs –the actual demand that drives supply chain output.
- C. Information Flow –the flow of relevant data that supports the flow of product and service.
- D. Linking customers/suppliers – key interfaces with customers and suppliers impacting the movement of goods and services.
- E. Cash Flow – impact on income statement that directly affects profitability.

A lean supply chain integrates ALL five (5) aspects from internal order fulfillment to external work performed by third party contractors, suppliers, distribution networks and service providers. These activities determine what work need to be performed, how it needs to proceed, who is going to do it, and the priority in which it is processed and completed. Internal logistics focus on the relationship linking procurement, production, and delivery of goods in a seamless process. External logistics links the operations with suppliers, service providers, contractors, and customers.

The key supply chain processes are procurement, customer service, warehouse, planning, distribution, transportation, information systems, and inventory control. Activities that emanate from these key processes are sales, planning, order entry, receiving, shipping, inspection, purchasing, production scheduling, master scheduling, warehouse management, and supplier management among others. (See Figure 1). These functions and activities represent an average between 4% and 20% of sales. In a synchronized manner, these key processes provide a seamless and well-coordinated supply chain to respond to customers and end-users. The goal of the lean supply chain is to deliver products at the lowest total cost while developing value-added processes (as defined by the customer).

FIGURE 1: SUPPLY CHAIN MANAGEMENT

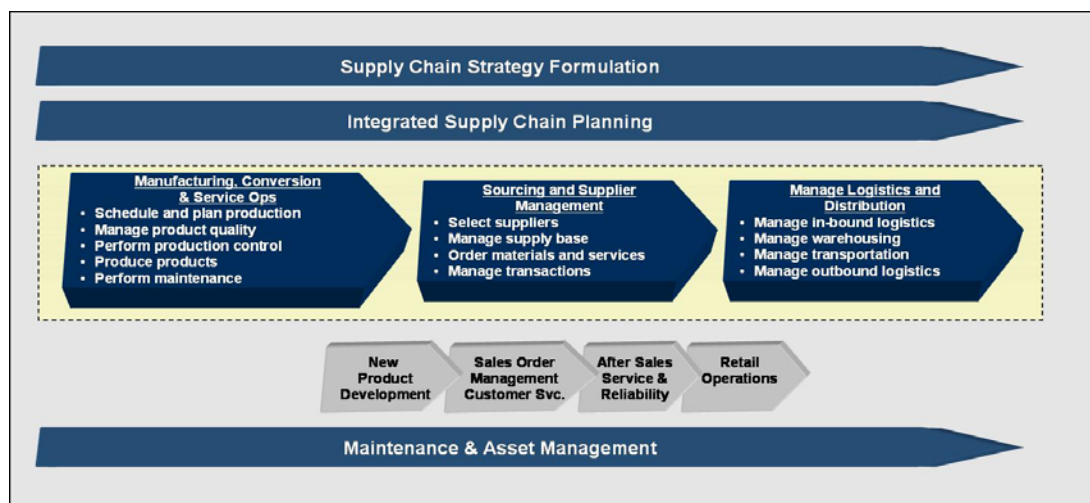

Value-added in terms of linking processes and activities, is described as “delighting the customer through a continuous stream of value-added activities”, or “adhering to the highest standards of business performance as measured by the customer”. As value is identified to individual activity, value streams are identified with the lean supply chain. The most effective method of identifying value and “value streams” is process mapping and a value chain analysis. A comparison of value-added features and non-value added practices is a fundamental exercise in the development of any value chain in the lean supply chain.

A well-defined lean supply chain is characterized by processes that are considered core competencies by the organization and are supported by qualified suppliers and driven by customer needs. The relationship is depicted in Figure 2. Accordingly, organizations that emphasize lean supply chains, like new technology, align key processes and regard them as core competencies rather than manufacturing components and assemblies. As a result, new and current products and services are delivered to market faster and more efficiently.

FIGURE 2: LEAN FORECASTING, PLANNING, SCHEDULING, AND MANUFACTURING

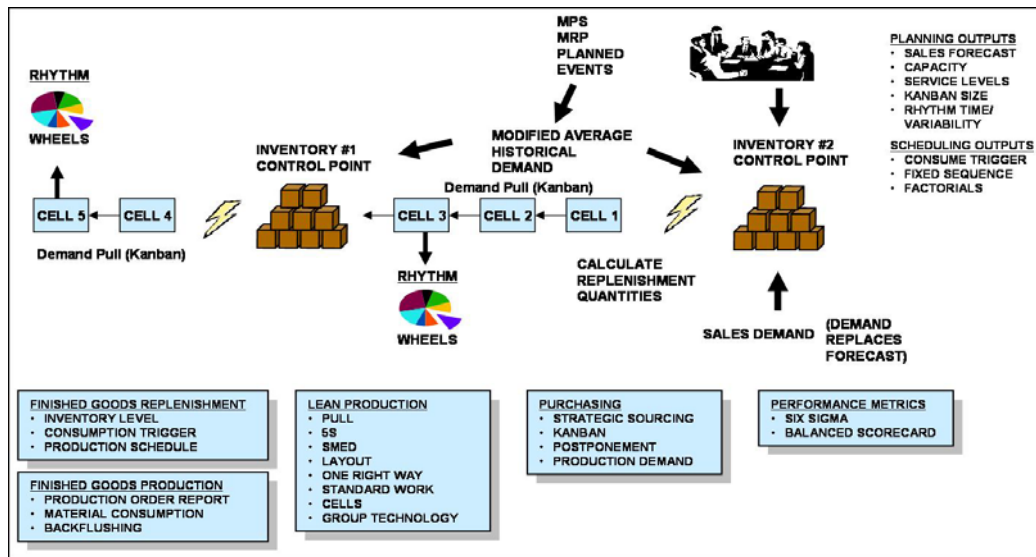

In the supply chain model defined in Figure 2, which outlines the chain that gets raw materials from suppliers to manufacturers and distributes them to consumers. Product Flow, Customer Demand, Information Flow, Linking Customers and Suppliers, and Cash Flow play a vital role in connecting the value stream. Although many alternatives are available, we will discuss these basic drivers because they are critical success factors in most supply chains. Supply chain optimization efforts begin with this core group of critical drivers as follows:

- A. **Product Flow** – In many supply chains, products tend to move forward in a “push” system. Under this system (in response to forecasts) inventory is built to a consistently high level which clearly strains working capital, while increasing leadtime, scrap, and rework. The opportunity to reduce inventory and non-value-added activity takes place when the supply chain is physically mapped and then redesigned. A primary result of this redesign is often an approach called Kanban. The Kanban technique allows for the radical change from a “push” to “pull” system which brings stock to the point of consumption only when it is needed for replenishment. A logistic system that links suppliers and customer requirements, Kanban provides a methodology for pulling only components that are required to meet immediate production requirements. The Japanese refer to Kanbans as a simple parts-movement system that depends on cards and boxes/containers to take parts from one work station to another. The essence of the Kanban concept is that a supplier or the warehouse will only deliver to the point of use as needed. Workstations located along the production lines only produce/deliver components when they receive a card and/or empty containers. Since Kanban is a chain process, production or delivery of components are pulled/issued to the production line. Kanbans drive the movement of materials from cell to cell in a modified pull system. Material is delivered to internal customers all along the supply chain in the shortest, unobstructed manner as requested by the user (See Figure 2).

- B. Customer Demand – Forecast is essential to the supply chain, if for no other reason, than to support financial planning. It provides rough-cut capacity planning data, and a basis for negotiating annual supplier blanket agreements. For the most part, it is used to provide information and data that provides projections and glimpses of the future. Beyond these features, the forecast has little value in day-to-day operations. The shift to customer actual demand requirements drive the execution of short-term schedules, daily production output, and supplier delivery requirements. Actual customer demand replaces forecast and is fed directly into the MRP System. Customer demands drive planning outputs, and internal/external schedules. Replenishment and work schedules are driven by customer demand, literally synchronizing ALL activities related to the supply chain. (See Figure 2).
- C. Information Flow – A robust supply chain must work with accurate information starting with forecasting to delivery of products to end-users. Supply and demand should be synchronized considering factors such as service levels, variability, events, and capacity as processed by technology platforms and users of the information. Virtual networks (e-commerce) links participants and activities including raw material suppliers, manufacturers, distributors, wholesalers, and consumers. Enterprise resource planning systems and the Internet are now the technology platforms that process information quickly and efficiently. As depicted in Figure 3, customer data is shown being processed in an ERP system supporting a “Pull System”. MPS, MRP, planned events, and internal/external schedules are driven by data that is actively received from customers. Inventory levels, consumption triggers, production schedules, order points, material consumption, and back-flushing activities are based on customer product requirements. In this case, data is used to share information (forecast) and the execution of production schedules and supplier delivery schedules. (See Figure 3).

FIGURE 3: REPLENISHMENT OF DEMAND FLOOR/KANBAN

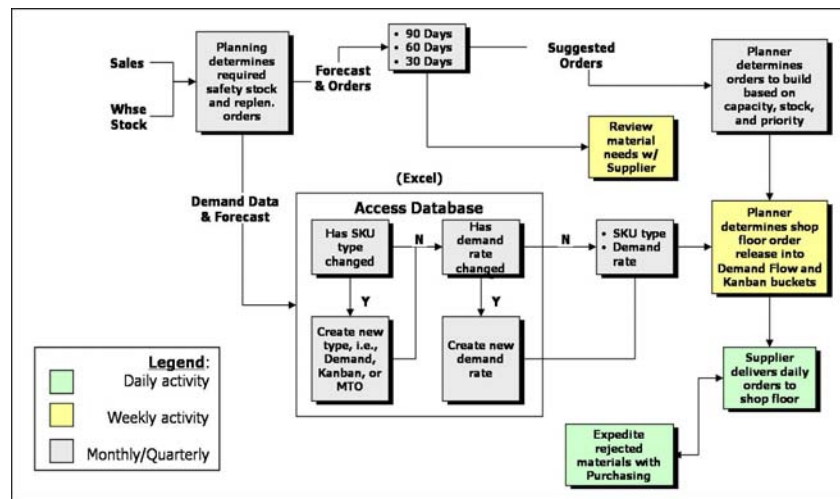

- D. Linking customers/suppliers – As total cost to the lean supply chain becomes an overall initiative, organizations are beginning to investigate the entire customer/supplier network for potential improvements. Outsourcing key production assemblies and production activity to suppliers who invest in equipment and projects that are mutually beneficial and share key information create barriers of trust throughout the supply chain. As trust is established and resources are pooled, satisfying customer needs at the lowest cost are attainable. An effective supply chain in any true partnership must include a list of customer needs and a selection of customers who can facilitate critical success factors. Techniques like Quality Functional Deployment (QFD) and “Voice of Customer” can be implemented to formalize the bridge between suppliers and customers. Suppliers are utilized to evaluate how they can help reach benchmarks. The value sought by suppliers is the reduction of total cost, improvement in quality, and achieving process improvements quickly and effectively. Suppliers are qualified and a small number are selected as partners. Essentially, a lean supply chain operates more efficiently with a reduced number of single-sourced suppliers. Concurrently, as part of the Supplier Qualification Process, raw material is certified to insure inspection-free reliable components are delivered directly to point of use. (See Figure 4).

FIGURE 4: PARTS CERTIFICATION, SUPPLIER QUALIFICATION PROCESS FLOW

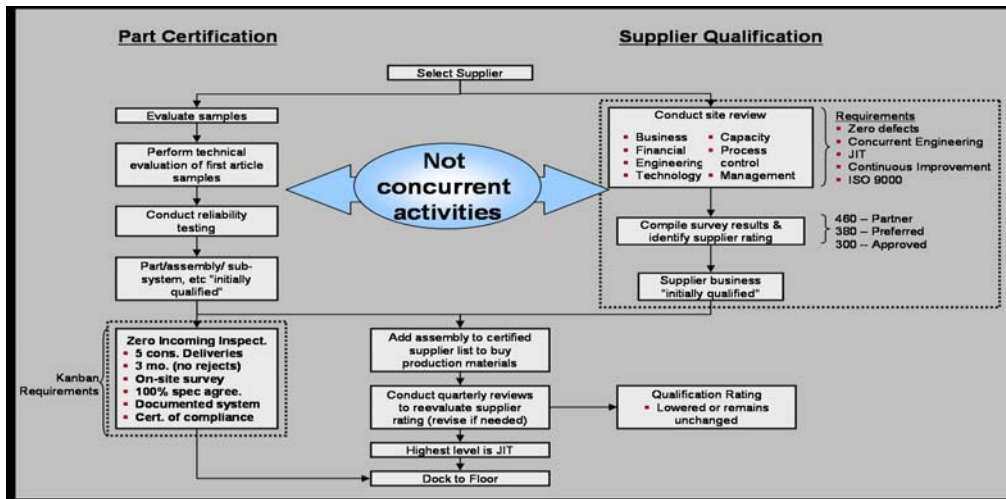

- E. Cash Flow – partnering with a reduced number of suppliers allows a more integrated quality, data sharing relationship. Leveraging purchasing power and introducing Just-In-Time concepts dramatically reduces total cost, creating value through Value Engineering and Design for Manufacturing (DFM). A supplier partnership maintains savings and strengthens the value stream throughout the supply chain. (See Figure 5).

FIGURE 5: STRATEGIC SOURCING

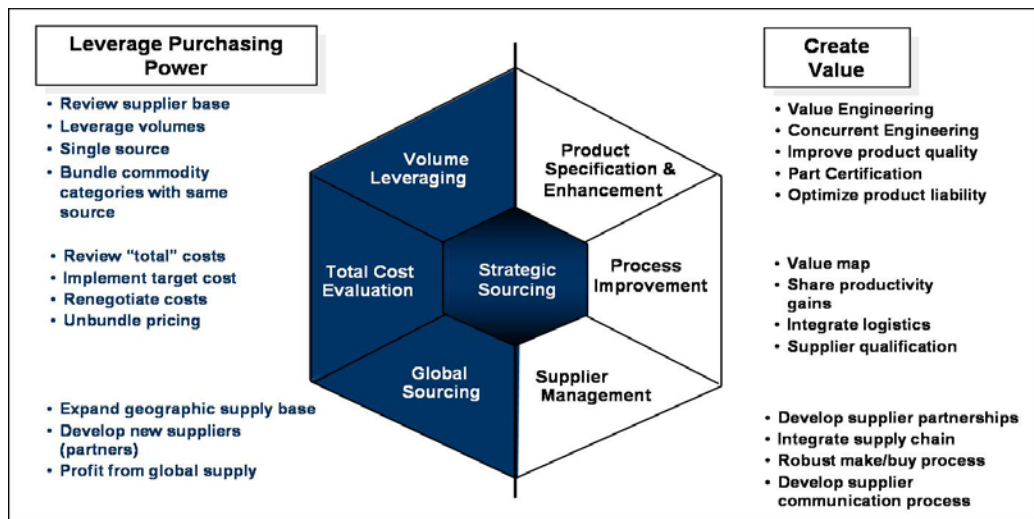

In the current environment, Procurement is becoming the “funding engine” for most supply reengineering projects for several reasons. First, purchasing as a percentage of sales can be as much as 90% and second, most procurement savings effect material costs that directly impact the financial bottom line. (See Figure 6). The following programs are replacing traditional supply chain techniques. These revised lean techniques and tools have a direct impact on the income statement and are the foundation of the front end of the lean supply chain.

- **Supplier Sourcing** – a prevalent method of material acquisition allowing the procurement team to select fewer suppliers in order to enhance volumes, to negotiate competitive pricing, and secure value-added services like JIT deliveries, Value Engineering, Vendor Managed programs, Certification (minimizing inspection, rework, rejects, and scrap).

- **Volume Leveraging** – volume leveraging is achieved through selecting suppliers with a wide variety of commodities, services, and resources in volume. Electronic and hardware suppliers are in the best position to provide a number of commodities in volume kit or assembled form delivered to the point of use.
- **Benchmarking** – benchmarking provides the vehicle for negotiating price reductions; a proactive procurement department will gage the market and keep their strategic suppliers in line with market conditions.
- **Supplier Consortiums** – an effective means of reducing procurement cost when leveraging and sourcing have been optimized with the current supplier base. Consortiums have been used to leverage manpower temp services, travel, MRO suppliers, certain raw material, and computer equipment.
- **Long-term Agreements** – LTA's with strategic partners enhance volume while reinforcing a true relationship that allows value-added activity like Value Engineering, Concurrent Engineering, and Vendor Managed Inventory (VMI).
- **Consignment** – the most immediate way to eliminate inventory and all the transactions related to the moving, inspection, and handling. Sometimes referred to as an In Plant Supplier Store.
- **JIT Deliveries/Stockless Program** –the most effective replenishment system with high volume commodities and expense items (i.e., nuts, bolts, and screws). Delivery to point of use, bypassing the traditional incoming warehousing minimizes lead-times and safety stock inventory..
- **Value-Added JIT Deliveries** – are most effective when bundling several commodities such as software and hardware, or production-related kits and assemblies that support product lines. Bundled commodities or assemblies reinforce the strategy of using different commodities to enhance volume with a single source supplier.
- **Value Engineering** – sometimes identifies the quickest means to eliminate unnecessary material or activity that may relate directly to material and labor reductions. Standardization of a commodity, process, or transaction is the most widely Value-Added method used to reduce cost.

The effective use of any of these techniques and strategies in tandem can have a positive impact on cycle times, the elimination of non-value-added activity, inventory, and increased productivity. The immediate impact on the balance sheet and income statement and consequently the relief on working capital is a strong motivation for continuing efforts in reengineering of the supply chain.

FIGURE 6: FINANCIAL ANALYSIS

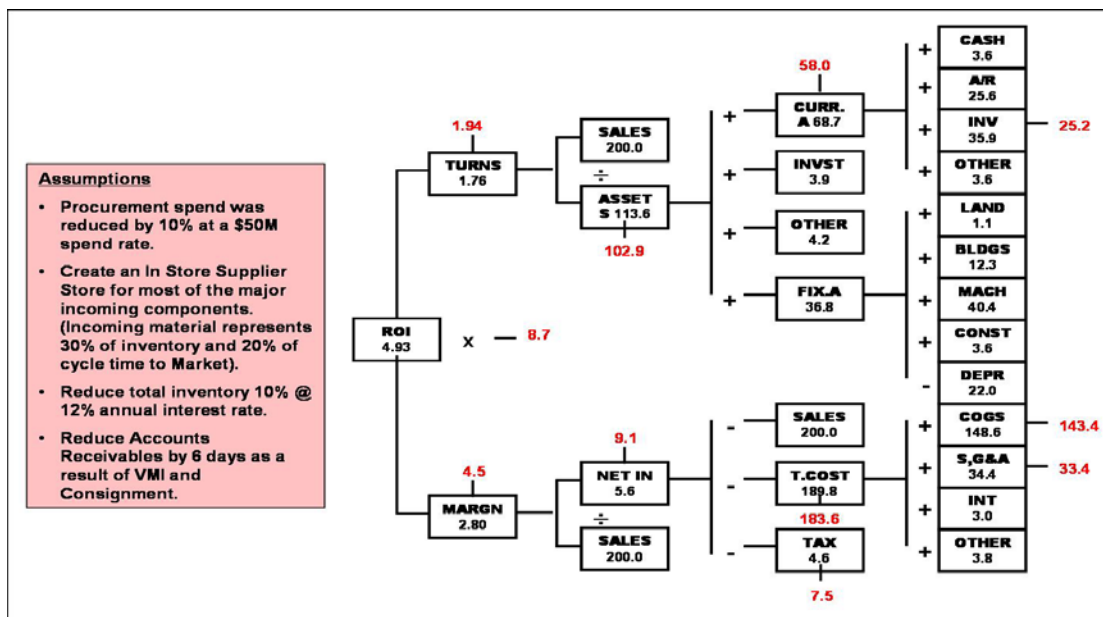

Transforming a disjointed supply chain into a lean supply chain requires a great deal of analysis and coordination. An organization must identify all non-value-added activity, address fragmented functions, adversarial supplier relationships, and an unwillingness to share important information. Basic processes such as order fulfillment, production and logistics flows need to be analyzed. Operational areas must be fully aligned with business strategies, goals, and performance metrics. Every relationship must be clearly defined and their impact on the value stream be understood. The performance of key suppliers and customers in terms of quality, delivery, and service should be expressed in relation to their impact to the financial bottom line. Finally, to optimize the value creation, all activity associated with the supply chain should have a close alignment with organizational goals and strategy.

As processes and activities are synchronized into a value stream, the lean supply chain transcends ALL functionally-driven strategies, techniques, and performance metrics. Although individual functions may be efficient, a well-coordinated number of key processes yield better results. How well a lean supply chain will perform is dependent on the maintenance of optimized and synchronized processes, established world class suppliers, and meeting customer needs. Remember, the key to any efficient supply chain is to eliminate the cause for the pause, match demand to production and single source suppliers.

This article was originally published in the May, 2002 issue of PharmaChem Magazine through B5srI. <http://www.b5srI.com>.